

# carrera 1000 PC



[www.ilapak.com](http://www.ilapak.com)



## TECHNICAL SPECIFICATIONS

<b>Machine speed</b>	Up to 130 cpm, single jaw. Higher speeds with multiple jaws Production output dependent upon product, film and machine specifications.
<b>Product dimensions</b>	
LENGTH	50/550 mm - 2/21.6" with any jaw centres and length
WIDTH	20/230 mm - 0.8/9" with jaw length 250 mm - 9.8" 20/300 mm - 0.8/11.8" with jaw length 325 mm - 12.8"
HEIGHT	Up to 90 mm - 3.5" with jaw centre 150 mm - 5.9" Up to 120 mm - 4.7" with jaw centre 180 mm - 7.1"
<b>Film cut-off</b>	Up to 630 mm - 24.8" Cut-off defined as: product length + height + 40 mm (1.6"), depending on product characteristics.
<b>Wrapping materials</b>	Suitable heat-sealable films, such as plain, or co-extruded polypropylene (PP), laminate films (e.g. OPP+PE), polythene films (PE) as well as cold-sealable films of suitable quality
<b>Film reel dimensions</b>	
CORE Ø	76 mm - 3"
OUTER Ø	350 mm - 13.8"
WIDTH	650 mm - 25.6"
<b>Film reel max weight</b>	40 kg - 88 lbs
<b>Electronic platform</b>	Industrial PC
<b>Power requirement</b>	From 220 to 480 V, 50/60 Hz, 3-phase, 5 kVA
<b>Compressed air</b>	6 bar, 1 l/min with air gusseting
<b>Machine weight</b>	900 kg - 1984 lbs

## MAIN STANDARD FEATURES

PC-controlled HFFS machine with rotary sealing jaws.

Multi-axis drive technology with 3 independent drive circuits, consisting of an AC motor controlled by a frequency inverter, for product infeed, sealing rollers and rotary sealing jaws.

A simple-to-use operator interface allows quick product change-over.

64 program memory; two-level password protection security.

Automatic adjustment of film-pull, infeed and sealing parameters during product or program change.

Precision temperature control circuits ensure seal strength and quality.

No product/No bag.

Misplaced product detection system.

Single piece transparent guarding with safety interlock.

Robust mechanical construction with welded sheet metal main body, epoxy powder coating or (opt.) stainless-steel finishing.

Hygienic design with cantilevered body and infeed, for easy clean down.

Single film reel mounting with self-centering cones, right hand machine version, 2 m long infeed, standard.

In-line and right-angle types of automatic feeders available on request.

Please discuss your needs with our local representative to configure this machine to your product's specific requirements.

ILAPAK is ISO 9001:2000 certified.

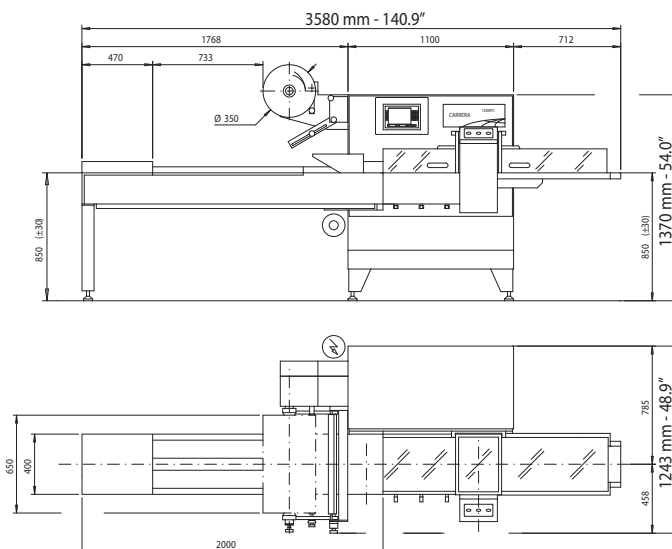

All measurements not specified in inches are given in millimeters.

These specifications are not binding. We reserve the right to change them without prior notice.



**WAGNER  
PACKAGING  
MACHINERY**

T: 972-385-9456

F: 972-596-3619

wagnerpkg@verizon.net / www.wagnerpkg.org